

# ector Industries, Inc.

W220 N1560 Jericho Court, Waukesha WI 53186

## High Pressure Funnel Style Bypass Feeder

(Comes Furnished With Funnel & Gate Valve)

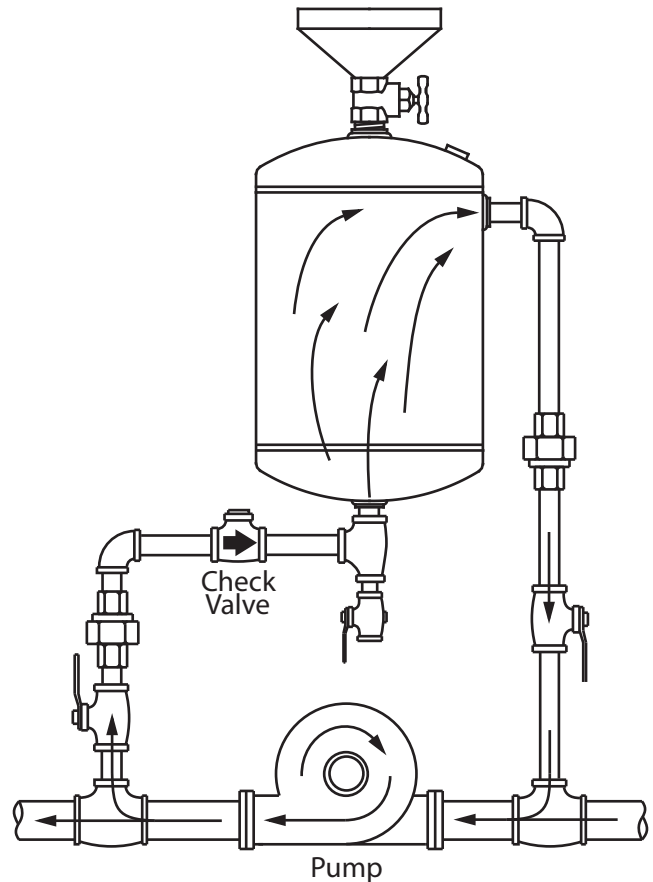
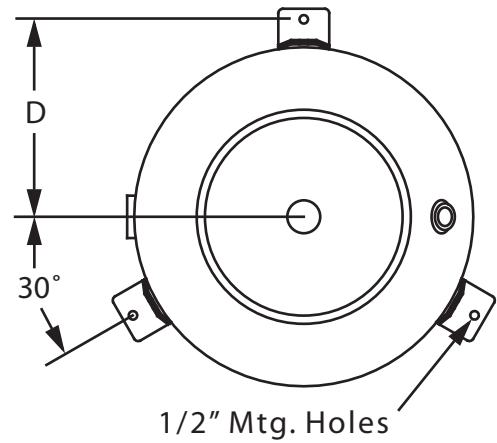
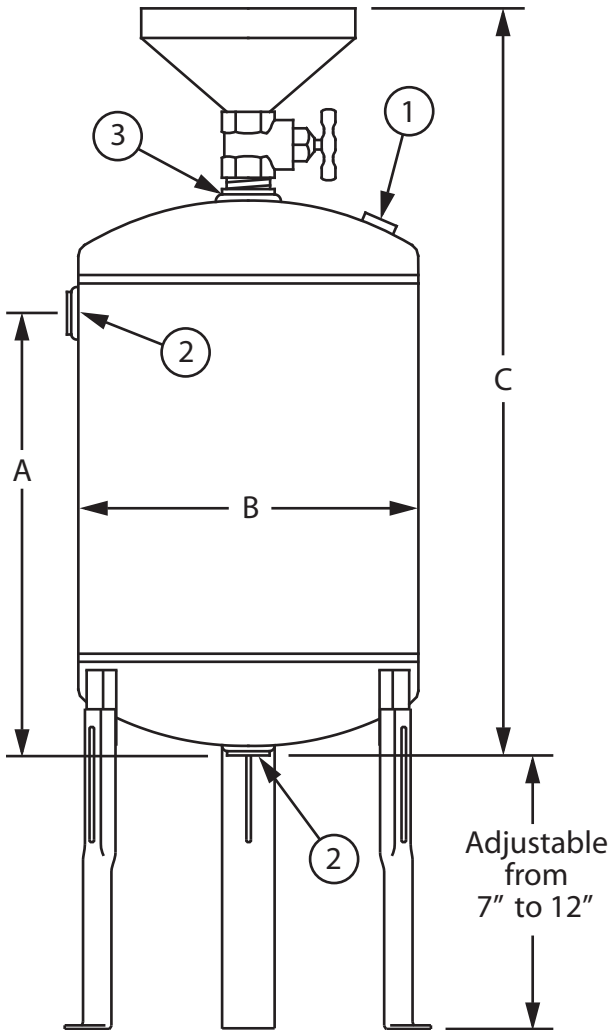

- ① 1/4" Female NPT Fitting
- ② 3/4" Female NPT Fitting
- ③ 1" Female NPT Fitting

Model	Approx. Capacity	A	B	C	D	Shipping Weight
FA-500	2 Gallons	12"	7"	22-1/2"	N/A	21 lbs
FA-500AL	2 Gallons	12"	7"	22-1/2"	4-1/2"	23 lbs
FA-600	5 Gallons	13"	10"	24"	N/A	29 lbs
FA-600AL	5 Gallons	13"	10"	24"	6"	32 lbs

Max operating specifications of 300psi (13.8bar), 300°F (149°C)  
Models with "AL" suffix include adjustable leg set (AL105)